



MARS Series

Intelligent On-Line UPS

Intelligent On-Line UPS

- Unity Input Power Factor
- Single-Chip Microprocessor Control
- Wide Input Voltage Range
- Pure Sinewave Output
- Smart RS-232 Communication Interface
- External Battery Cabinet Connectivity



Mars Series Intelligent On-line UPS

In today's world we are heavily reliant on technology and the power that drives it. If you do not have the correct protection you are putting your business at risk of downtime, lost data and even component damage. The intelligent Mars series is a cost effective way of meeting your critical power needs and integrates seamlessly into the modern network environment.



Outstanding Features:

Unity Input Power Factor

The Mars series meets today's industry standard for energy saving and low reflected harmonic pollution to the utility.

Single-Chip Microprocessor Control

The Mars series uses a field proven MPU to substantially reduce the component count. This provides greater reliability, functionality and smaller size than other designs. Using the latest high frequency techniques and quality components reliability is further increased. High system efficiency is achieved in all operating modes saving electricity.

Double Conversion On-line Technology

Completely re-generates the utility power to correct the power disturbances in the Mains. The unit provides clean A.C. power 24 hours a day 365 days a year.

User Friendly Display

The front panel clearly communicates all major system parameters and system status including load level, battery remaining and fault status for easy service.

Block Diagram of Mars Series UPS

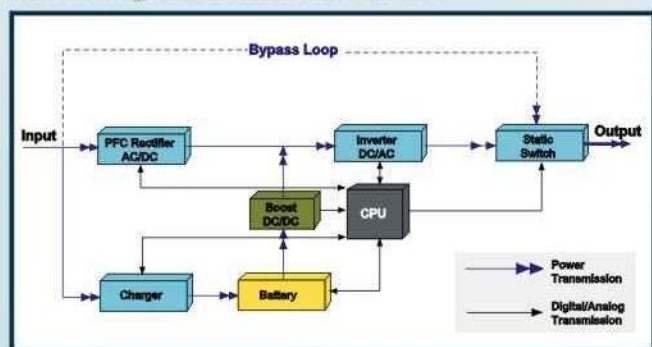

MARS Series

User-friendly Plug and Play Design

The Mars series can easily be installed by the end user.. All units up to 2KVA are supplied with input cables and IEC output cables as standard. For convenience, we also add local sockets in addition to IEC outlets.

Complete Protection Circuitry

The Mars series was designed with today's technology in mind and is particularly suited to computer and telephony switch mode power supplies.

Through careful design maximum security is provided to the load. In particular the units feature high overload handling without transfer to bypass. Short circuit and over temperature are protected as standard.

The input PFC circuitry can handle very wide ranges of AC input voltages to avoid the frequent use of battery energy. Consequently, the system security and battery life can be maximised ensuring that the batteries are available when you need them most..... Power failures!



Customer Options Slot



A true RS232 communication port is supplied as standard with each UPS. This can be used with the software provided or an external SNMP adapter. The Options slot allows further flexibility in network configuration. Three cards are available: an internal SNMP card, AS400 card or a true relay card to provide isolated contacts for industrial and remote alarm panel applications.



AS400 card



True Relay Interface Card

MARS Series

Matching Battery Cabinet

Standard matching battery cabinets are available to easily extend the UPS runtime to several hours. The battery cabinets are available with their own independent chargers to provide safe and fast recharging.



Smart Battery Management System (SBM)

Smart battery management system monitors the battery charging and discharging status.

Communication

The Mars series are all shipped with shutdown software as standard. The software allows not only the control of the UPS and graceful shutdown when the utility fails, but also allows the user to:

- remotely test the major operating functions of the UPS
- communicate via SNMP/web/network adapter
- access UPS functions via the web
- alert users via SMS messages against specific events

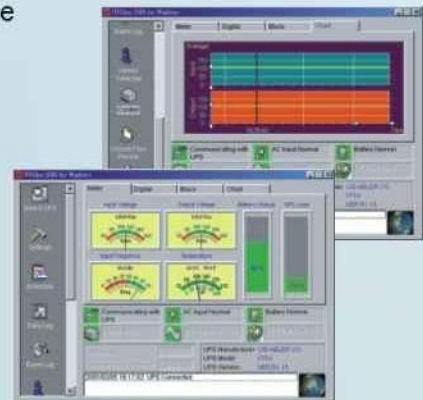

The free software supplied supports Novell Netware, Windows 95/98/2000/Me/XP/NT, Linux and FreeBSD. Major Unix platforms are available as a cost option.

Industrial 19" Rack-Mount models

The Mars series UPS are available in robust 19" industrial Rack-Mount enclosures.

The 19" matching Rack-Mount battery cabinets are also available for long runtime applications. All rack models have a facility for the user to easily change the batteries at the end of useful service life.



Run Time Reference

Load	MS1000/MS1000R	MS2000/MS2000R	MS3000/MS3000R
400VA/280W	28 Min	63 Min	96 Min
800VA/560W	9 Min	25 Min	72 Min
1000VA/700W	8 Min	17 Min	24 Min
1500VA/1050W		10 Min	18 Min
2000VA/1400W		8 Min	14 Min
2500VA/1750W			10 Min
3000VA/2100W			8 Min

Technical Specification

MODEL	MS1000	MS2000	MS3000	MS1000R	MS2000R	MS3000R
INPUT						
Voltage (Vac)	80~140 or 160~280					
Frequency (Hz)	50 / 60±5% (Auto. Sensing)					
Phase	Single					
Input Power Factor	> 0.98 (full load)					
OUTPUT						
Voltage (Vac)	100/110/120/127Vac or 200 / 220 / 230 / 240					
Capacity (VA/W)	1000VA/700W	2000VA/1400W	3000VA/2100W	1000VA/700W	2000VA/1400W	3000VA/2100W
Rated Power Factor	0.7 Lagging					
Load Power Factor Range	0.5 Lagging to Unity within KW rating of unit					
Wave Form	Sine Wave ,THD < 3% (no load to full load)					
Voltage Regulation	±2%					
Transient Response (ms)	±4% under full load, change and corrected within 60 ms					
Frequency Stability	±0.5% (Free Running)					
Synchronization	Slew Rate: 1Hz/Sec. Max. Synchronizing Window ±5%					
Transfer Time	0 ms					
Crest Factor	3 : 1					
Efficiency (AC to AC)	up to 88%					
Run Time (Full Load)	8 min.	8min.	8min.	8 min.	8min.	8min.
DC Start	Yes					
BATTERY						
Type	Sealed Lead Acid Maintenance Free					
Quantity (Pcs)	3	6	8	3	6	8
Voltage (Vdc)	36	72	96	36	72	96
Recharge Time	8 Hours To 90%					
Supplementary Charger	Optional 200W/500W Charger for extended back-up application					
DISPLAY						
LED	Utility, Battery Low, Inverter, Bypass, Self Test, Over Load, Load/Battery Level, and Fault Conditions					
SELF DIAGNOSTICS	Push Button (On Demand)					

MARS Series

MODEL	MS1000	MS2000	MS3000	MS1000R	MS2000R	MS3000R
PROTECTION						
Overload	AC Mode: 1)<105% continuously. 2)105% ~ 120% delay 50 seconds before switching to bypass 3)120% ~150% delay 10 seconds before switching to bypass 4)>150% immediately switching to bypass Backup Mode: Same delay time as AC mode, then complete shutdown.					
Short Circuit	Hold Whole System					
Overheat	Switch to Bypass					
High Voltage Trip	Switch to Backup Mode					
Battery Low	Alarm and Switch Off					
Noise Suppression	Complies with EN50091-2					
Spike Suppression	Complies with EN61000-4-5					
ALARM						
Audible and Visual	Line Failure, Battery Low, Transfer To Bypass, Over Load, System Fault Conditions					
PHYSICAL						
Dimensions (WxHxD, mm)	147x223x401	130x365x479	190x365x453	443x88x385	443x132x481	443x176x482
Outlets (NEMA)120Vac	4x5-15R	2x5-12R +2x5-20R	Terminal + 1x5-30R	4x5-15R	2x5-15R +2x5-20R	Terminal+ 1x5-30R
Outlets (IEC/Local) 230Vac	3pcs/1pce	3pcs/2pcs	Terminal/2pcs	3pcs/1pce	3pcs/2pcs	Terminal/2pcs
Net Weight (Kgs)	15	27	36	16	29	39
ENVIRONMENT						
Temperature	0°C~40°C					
Temperature Warning	The battery design life is based on a temperature of 25°C Ambient temperature above this range will reduce battery life					
Altitude	0~2000m up to 40°C, 3000m up to 35°C					
Humidity	90% RH Maximum, Non-Condensing					
Noise	<45 dB (at 1 meter)					
COMPUTER INTERFACE						
Interface Type	Standard RS232 Interface					
Protocol	MegaTec Protocol					
Compatibility of Bundled Software	UPSilion 2000 for Novell NetWare, Windows 95/98, Windows NT, Windows ME, Windows 2000, Windows XP or other Windows Operation Systems, Linux and Free BSD					
SNMP Adaptability	Slot for Standard SNMP Card (optional)					
AS400 Card or True Relay Interface Card	AS400 card or True Relay Interface Card provides , Utility Failure, Battery Low, Bypass Active, UPS Shutdown functions .(optional)					
Optional Software	UPSilion for Unix, SNMP Adapter, USBMate, etc.					
SAFETY CONFORMANCE						
Quality Assurance	ISO9001 Certified Company					
Safety Standard	EN50091-1, UL					
EMC Standard	EN50091-2, EN61000-3-2, EN61000-3-3, FCC Class A					
Marks	CE, UL					

*Above specifications are subject to change without prior notice.

 **AblereX** UIS ABLER ELECTRONICS CO., LTD.

1F., No.3, Lane 7, Paokao Rd., Hsintien 23114
Taipei Hsien, Taiwan R.O.C.
TEL:886-2-2917-6857
FAX:886-2-2913-1705
<http://www.uisabler.com.tw>
e-mail:uisabler@uisabler.com.tw

