

INPUT PLUG: 16A IEC320 C20

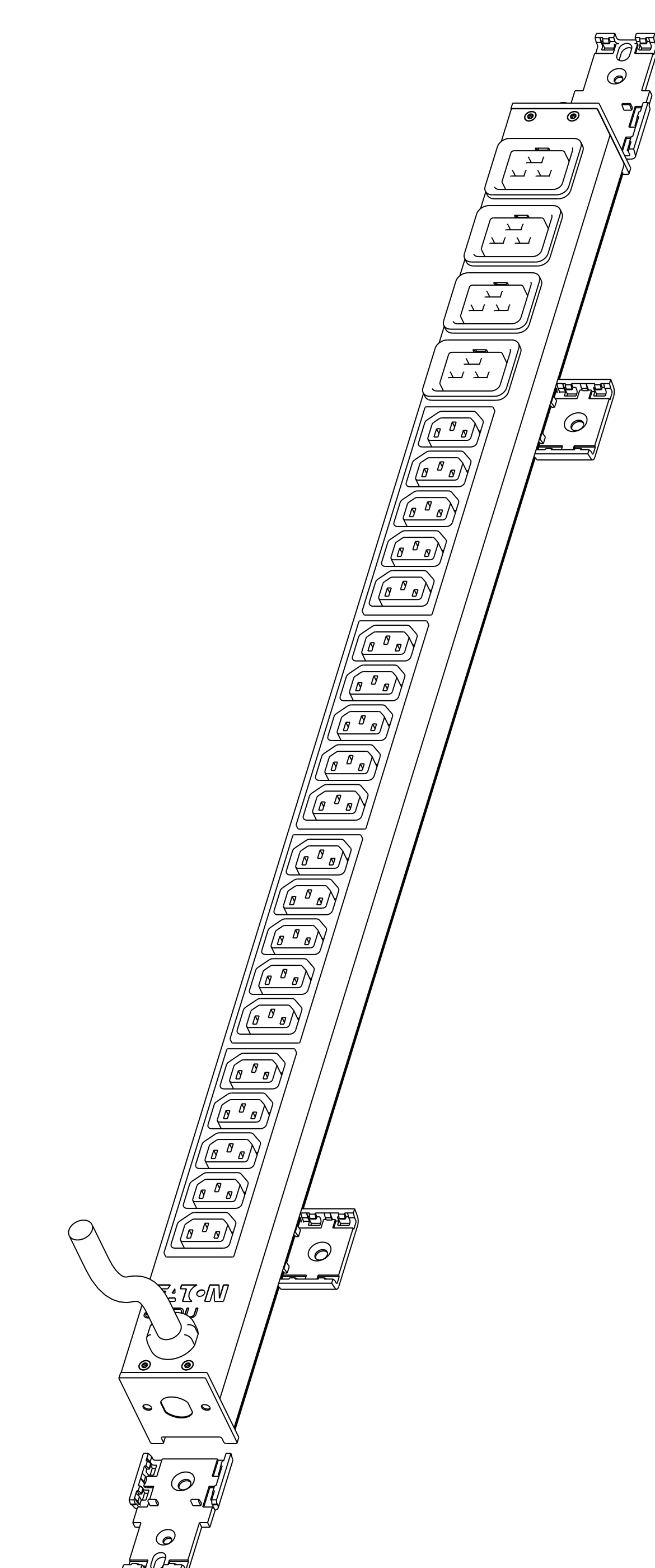
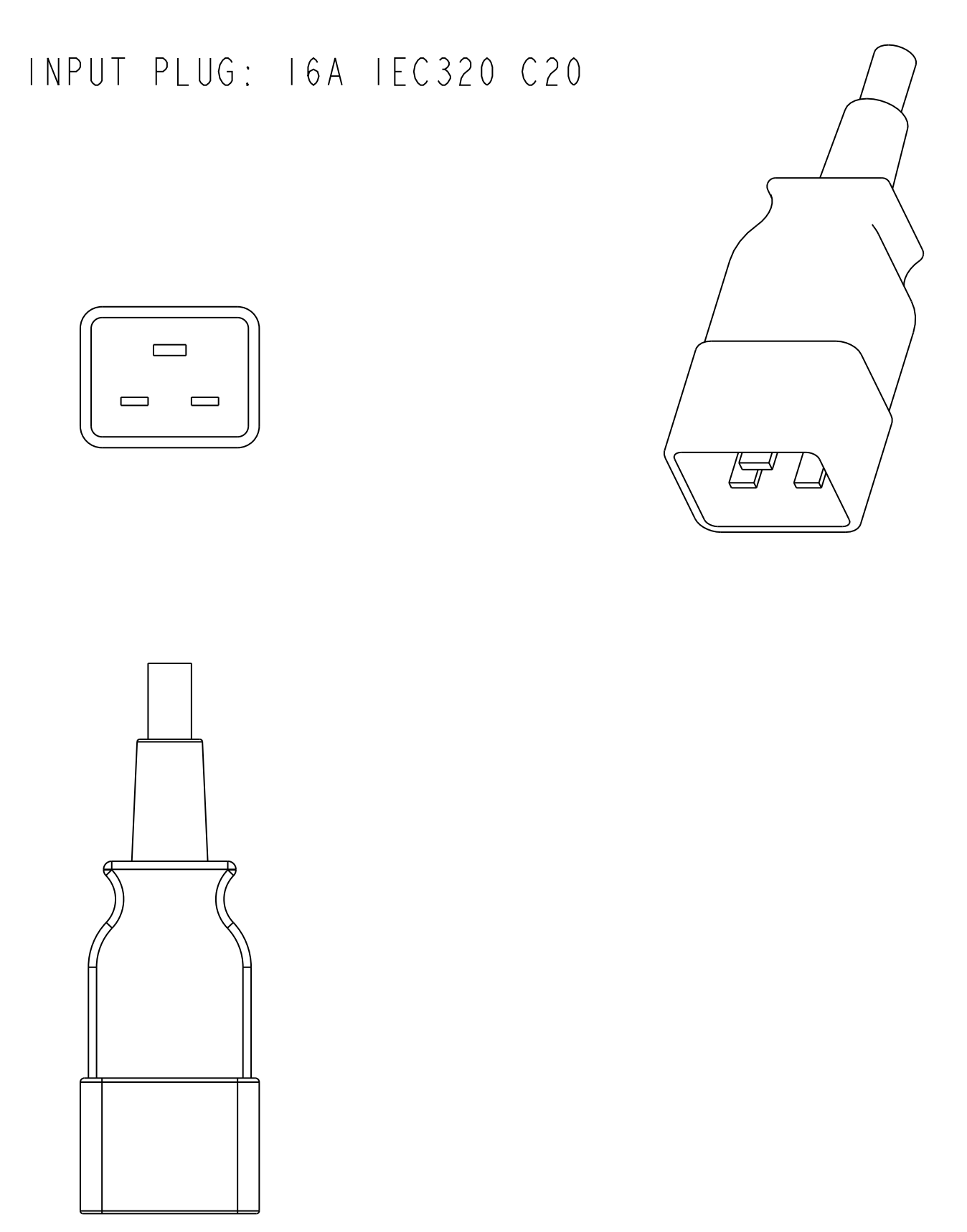

DESCRIPTION : ePBZ33 Eaton ePDU Basic 16A IN: C20 OUT: 20 x C13 + 4 x C19  
 CORDESET: 3M 1.5SQmm CABLE WITH 16A IEC320 C20 PLUG  
 RECEPTACLES: 20xIEC320 C13 ( 5 way block 10A rated) + 4xIEC320 C19 (16A rating)  
 PROTECTION: N/A  
 INPUT RATING: 16A / 240V AC  
 CERTIFICATION: CE MARKET TO EN60950-1

B Updated		14.06.2010	FLB	FLB
A Updated length		30.04.10	FLB	FLB
REV. MODIFICATION	DATE	DESIGNER	VERIF.	
EATON		1:1		
CH-1345 LE LIEU SWITZERLAND		DESIGNED BY / DRAWN THE	19.03.2010	
TOLERANCE GENERALE / GENERAL TOLERANCE		VERIFIE PAR / VERIFIED BY	FLB	
NIVEAU DE CERTIFICAT DE SOUMISSION REQUIS / SAMPLES APPROVAL PROCESS REPORT		DIMENSIONS AND TOLERANCES IN MILLIMETERS		
DESIGNATION	ePBZ33	SH-16116-10		
INSPECTION DIMENSIONS	[XX.XX]	FUNCTIONAL DIMENSIONS	XX.XX	REV.
Ce document est propriété de Eaton Industries Manufacturing GmbH. Duplication interdite sans autorisation. This document is Eaton Industries Manufacturing GmbH property. Duplication forbidden without authorization.				